

# Data Bulletin

Replaces 3110DB0401 11/2007

## Direct Current and Photovoltaic Systems Applying Heavy Duty Safety Switches (Fusible and Non-Fusible) on dc and Photovoltaic Systems Class 3110

Retain for future use.

### General dc and Photovoltaic Systems, UL® Listed, CSA® Certified (Files E2875 and E154282)

**NOTE:** Heavy duty safety switches may be used on photovoltaic systems with a grounded feed. Refer to Figures 1B, 1D, 1F and 2 (negative grounding shown; positive grounded systems are similarly allowed). For ungrounded systems, see National Electrical Code® (NEC®) 690.35 (NEC 2008, NFPA 70).

All heavy duty safety switches with dc ratings (2-, 3- and 4-pole fusible and non-fusible) are Underwriters Laboratories® (UL®) Listed and CSA® Certified for use on dc applications when wired as shown in Figure 1 (A, B, C, D, E, and F). Additionally:

- Heavy duty safety switches are rated for 600 Vdc maximum open circuit voltage.
- Non-fusible safety switches may carry 100 percent of the nameplate current rating.
- Fusible safety switches may carry 80 percent of nameplate current rating (continuous use).
- Heavy duty switches are dc horsepower rated as indicated on the safety switch wiring diagram.
- Heavy duty switches have a 10,000 ampere dc short-circuit rating at 600 Vdc unless otherwise stated on the switch wiring diagram. Consult factory for short circuit current ratings at 250 Vdc.
- Refer to current Square D® Digest for lug wire range of heavy duty switches.

Figure 1: General dc and Photovoltaic Systems, Fusible and Non-Fusible Wiring Diagram

(Non-Fusible Shown)

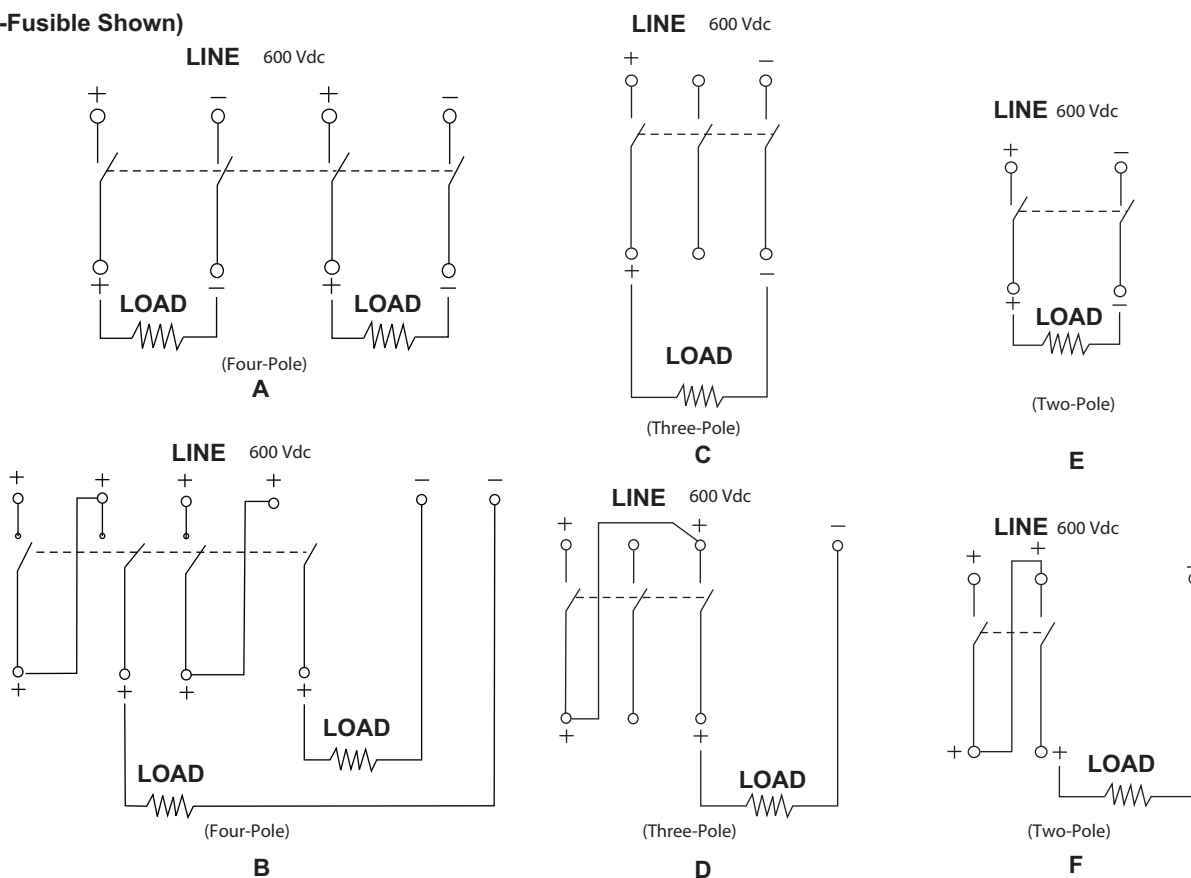

**Alternate Photovoltaic System  
Wiring, Evaluated and  
Self-Certified by Schneider Electric**

**Not UL Listed**

**Figure 2: Grounded Feed per NEC Article 690**

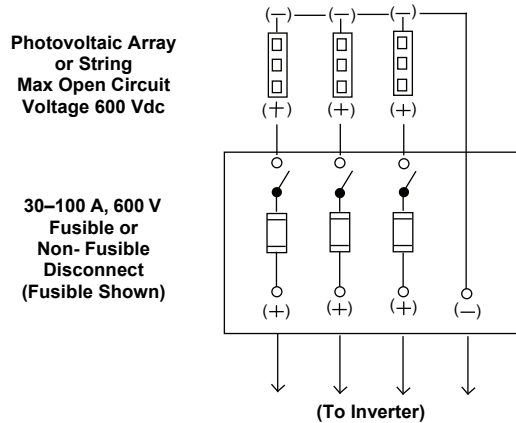

- Connect negative photovoltaic line (-) to case inside inverter for negative grounded system.
- Positive grounded systems are similarly allowed.
- For ungrounded systems, see NEC 690.35 (NEC2008, NFPA70).

**Current Ratings**

Switch Nameplate 600 V	Switch dc Rating per Pole <sup>1</sup>	Photovoltaic Maximum Circuit Current <sup>2</sup>	Photovoltaic Short-Circuit Current (I <sub>sc</sub> )
30 A	20 A	16 A dc per pole	12.8 A (20/1.56)
60 A	60 A	48 A dc per pole	38 A (60/1.56)
100 A	100 A	80 A dc per pole	64 A (100/1.56)

<sup>1</sup> The switch per pole rating must be at least the photovoltaic maximum circuit current multiplied by 125%.

<sup>2</sup> From NEC 2008 and NFPA 70, Article 690.8: the photovoltaic maximum circuit current is I<sub>sc</sub> multiplied by 125%.

- If a non-fusible disconnect is used, the inverter must not be capable of backfeeding currents into a short circuit or fault in the photovoltaic array or string.
- One inverter may be connected to each pole of the switch.
- Refer to current Square D Digest for lug wire range of heavy duty switches.

**Schneider Electric**  
1601 Mercer Road  
Lexington, KY 40511 USA  
1-888-SquareD (1-888-778-2733)  
www.schneider-electric.us

Square D® is a trademark or registered trademark of Schneider Electric. Other trademarks used herein are the property of their respective owners.

Electrical equipment should be installed, operated, serviced, and maintained only by qualified personnel. No responsibility is assumed by Schneider Electric for any consequences arising out of the use of this material.