

# THE GROUNDING AND BONDING PAMPHLET

Summarizing the Basic Requirements  
of Article 250 of the 2002 NEC  
for Typical Premises Wiring Installations  
(50 to 1,000 Volts)



Prepared by  
The Southwestern Section  
International Association of Electrical Inspectors  
2002 Grounding and Bonding Committee

William Brownell, P.E., Chairman  
Doug Effenberger, P.E.                      Gerald Williams  
Jim Moore    Chuck Leisher  
Timothy Owens                                      Jesus Mosqueda  
Steve Schinko                                        Jim Palma  
Ron Takiguchi, P.E.                                Nader Shams, P.E.

Tom Trainor\*

\*Special thanks to Tom, whose efforts were indispensable in this rewrite.

The objective of the IAEI shall be:

- To cooperate in the formulation of standards for the safe installation and use of electrical materials, devices, and appliances.
- To promote the uniform understanding and application of the National Electric Code and other electrical codes.
- To promote cooperation between inspectors, the electrical industry, and the public.
- To collect and disseminate information relative to the safe use of electricity.
- To represent the electrical inspectors in all matters which are dealt with nationally and internationally by the electrical industry.
- To cooperate with other national and international organizations in furthering the development of the electrical industry.



# THE GROUNDING AND BONDING PAMPHLET

## Table of Contents

Purpose and Scope . . . . .	1
Background . . . . .	1
Recommended Reference . . . . .	1
Acknowledgement . . . . .	1
Disclaimer . . . . .	1
Definitions From Article 250 . . . . .	2
Related Definitions From Article 100 . . . . .	2
General Performance Requirements for Grounding and Bonding . . . . .	4
Which Services to Ground . . . . .	5
How to Ground Them . . . . .	6
Connecting the Grounding Electrode Conductor . . . . .	7
Grounding at Separate Buildings . . . . .	8
Service Bonding . . . . .	10
Bonding Service Equipment . . . . .	11
Bonding Other Electrical Equipment . . . . .	12
Other Bonding . . . . .	12
Equipment Grounding (Bonding) . . . . .	13
Grounding Electrodes . . . . .	14
Grounding Electrode Conductors . . . . .	14
Grounding Electrode System . . . . .	15
Made Electrodes . . . . .	17
Grounding Electrode Conductor . . . . .	19



## **PURPOSE AND SCOPE**

The purpose of this pamphlet is to review the requirements of Article 250 in the 2002 NEC. The pamphlet will focus on the requirements for typical electrical installations of 600 volts or less. The goal is to clarify the grounding and bonding requirements and to show installation methods that comply with Article 250.

### **BACKGROUND**

Article 250 has undergone significant revision in both the 1999 and 2002 editions of the NEC.

The intent of this work was to make the article easier to read and understand.

One of the most important changes was the addition of Article 250.4 (250-2 in the 1999 edition) which provides performance requirements for grounding and bonding.

Performance requirements are helpful since they actually define what grounding and bonding are intended to accomplish in the electrical system.

Article 250 now clearly states that grounding performs a specific function in the electrical system and that bonding performs a separate and distinctly different function.

The 1999 NEC introduced the term "Fault Current Path" to better describe the necessary function performed by bonding.

The 2002 NEC adds definitions of Ground-Fault, Ground-Fault Current Path and Effective Ground-Fault Current Path.

These definitions, in conjunction with the performance requirements, help to explain the "why" of grounding and bonding requirements.

### **RECOMMENDED REFERENCE**

The IAEI "Soares Book on Grounding" is highly recommended for further study on this subject.

---

### **ACKNOWLEDGEMENT**

Sections of NFPA – 70, the 2002 edition of the National Electrical Code are reproduced in this pamphlet for educational purposes only.

### **DISCLAIMER**

The information in this pamphlet represents the informed opinion of the authors and is believed to be accurate but does not represent an official interpretation of the 2002 NEC.

The new requirements in Article 250 created three new technical terms. It is important to understand these terms and others related to grounding and bonding. For that reason, the following definitions are included for review and reference.

## DEFINITIONS FROM ARTICLE 250

The performance requirements in the 1999 NEC introduced the term, *Fault Current Path*. In the 2002 NEC, this term has been changed to *Effective Ground-Fault Current Path*. The following definitions found in Article 250.2 of the 2002 NEC are very helpful in understanding the intent of the performance requirements for grounding and bonding. Explanatory notes are in italics.

**Ground Fault** — An unintentional, electrically conducting connection between an ungrounded conductor of an electrical circuit and the normally non-current-carrying conductors, metallic enclosures, metallic raceways, metallic equipment, or earth.

*The key elements of a ground fault are that it is unintentional and that it can occur anywhere on the premises wiring system.*

**Ground-Fault Current Path** — An electrically conductive path from the point of a ground fault on a wiring system through normally non-current-carrying conductors, equipment, or the earth to the electrical supply source.

FPN: Examples of ground-fault current paths could consist of any combination of equipment grounding conductors, metallic raceways, metallic cable sheaths, electrical equipment, and any other electrically conductive material such as metal water and gas piping, steel framing members, stucco mesh, metal ducting, reinforcing steel, shields of communications cables, and the earth itself.

*Once a ground fault occurs, fault current will flow on any and all available paths to return to the source. The FPN was added specifically to make that very clear.*

**Effective Ground-Fault Current Path** — An intentionally constructed, permanent, low-impedance electrically conductive path designed and intended to carry current under ground-fault conditions from the point of a ground fault on a wiring system to the electrical supply source.

*Every element in this definition is necessary and important.*

***This path must be created on each and every circuit installed in order to have effective protection against a ground fault condition.***

## RELATED DEFINITIONS FROM ARTICLE 100

**Bonding (Bonded)** — The permanent joining of metallic parts to form an electrically conductive path that ensures electrical continuity and the capacity to conduct safely any current likely to be imposed.

**Bonding Jumper** — A reliable conductor to ensure the required electrical conductivity between metal parts required to be electrically connected.

**Bonding Jumper, Equipment** — The connection between two or more portions of the equipment grounding conductor.

**Bonding Jumper, Main** — The connection between the grounded circuit conductor and the equipment grounding conductor at the service.

**Ground** — A conducting connection, whether intentional or accidental, between an electrical circuit or equipment and the earth or to some conducting body that serves in place of the earth.

**Grounded** — Connected to earth or to some conducting body that serves in place of the earth.

**Grounded, Effectively** — Intentionally connected to earth through a ground connection or connections of sufficiently low impedance and having sufficient current-carrying capacity to prevent the buildup of voltages that may result in undue hazards to connected equipment or to persons.

**Grounded Conductor** — A system or circuit conductor that is intentionally grounded.

**Grounding Conductor** — A conductor used to connect equipment or the grounded circuit of a wiring system to a grounding electrode or electrodes.

**Grounding Electrode Conductor** — The conductor used to connect the grounding electrode(s) to the equipment grounding conductor, to the grounded conductor, or to both, at the service, at each building or structure where supplied from a common service, or at the source of a separately derived system.

**Premises Wiring System** — That interior and exterior wiring, including power, lighting, control, and signal circuit wiring together with all of their associated hardware, fittings, and wiring devices, both permanently and temporarily installed, that extends from the service point or source of power, such as a battery, a solar photovoltaic system, or a generator, transformer, or converter windings, to the outlet(s). Such wiring does not include wiring internal to appliances, luminaires (fixtures), motors, controllers, motor control centers, and similar equipment.

**Service** — The conductors and equipment for delivering electric energy from the serving utility to the wiring system of the premises served.

**Service Point** — The point of connection between the facilities of the serving utility and the premises wiring.

**Service Conductors** — The conductors from the service point to the service disconnecting means.

**Service Equipment** — The necessary equipment, usually consisting of a circuit breaker(s) or switch(es) and fuse(s) and their accessories, connected to the load end of service conductors to a building or other structure, or an otherwise designated area, and intended to constitute the main control and cutoff of the supply.

**Service-Entrance Conductors, Overhead System** — The service conductors between the terminals of the service equipment and a point usually outside the building, clear of building walls, where joined by tap or splice to the service drop.

**Service Drop** — The overhead service conductors from the last pole or other aerial support to and including the splices, if any, connecting to the service-entrance conductors at the building or other structure.

**Service-Entrance Conductors, Underground System** — The service conductors between the terminals of the service equipment and a point usually outside the building, clear of building walls, where joined by tap or splice to the service drop.

**Service Lateral** — The underground service conductors between the street main, including any risers at a pole or other structure or from transformers, and the first point of connection to the service-entrance conductors in a terminal box or meter or other enclosure, inside or outside the building wall. Where there is no terminal box, meter, or other enclosure, the point of connection is considered to be the point of entrance of the service conductors into the building.

**Editorial Note: The neutral conductor was originally named that because the voltage to earth from that conductor was zero or "neutral." It was renamed the "grounded conductor" because of the one exception where this is not true – the three wire, three phase, delta connected, corner grounded system. In this same change, the hot or live wire became the "ungrounded" conductor and the ground wire became the "grounding" conductor. While the code has been consistent in its use of these new terms, the terms hot, neutral and ground are still in common use in the electrical industry. In this pamphlet, the term "neutral" will be used interchangeably with "grounded conductor."**

## GENERAL PERFORMANCE REQUIREMENTS FOR GROUNDING AND BONDING

Section 250.4 identifies performance requirements for grounding and bonding. These requirements were introduced in the 1999 NEC and revised in the 2002. Performance requirements can be very helpful because, in describing what has to be accomplished, they tend to make the “why” of the requirement easier to understand.

250.4 and 250.4 (A) Grounded Systems are reproduced here for reference with **bold type** and notes in italic type added to emphasize the different functions performed by grounding and bonding. 250.4 (B) is omitted as this pamphlet does not cover Ungrounded Systems.

### 250.4 – General Requirements for Grounding and Bonding

The following general requirements identify what grounding and bonding of electrical systems are required to accomplish. The prescriptive methods contained in Article 250 shall be followed to comply with the performance requirements of this section.

#### (A) – Grounded Systems

**(1) – Electrical System Grounding – Electrical systems** that are grounded **shall be connected to earth** in a manner that will **limit the voltage** imposed by **lightning, line surges**, or unintentional **contact with higher-voltage lines** and that will **stabilize the voltage** to earth **during normal operation**.

*The electrical system is connected to earth to provide a path for lightning and high voltage which provides some protection from these hazards. This connection also helps to stabilize voltage.*

**(2) – Grounding of Electrical Equipment – Non-current-carrying conductive materials** enclosing electrical conductors or equipment, or forming part of such equipment, shall be **connected to earth** so as **to limit the voltage to ground** on these materials.

**(3) – Bonding of Electrical Equipment – Non-current-carrying conductive materials** enclosing electrical conductors or equipment, or forming part of such equipment, shall be **connected together and to the electrical supply source** in a manner that establishes **an effective ground-fault current path**.

*Electrical equipment is connected together and to the neutral to provide a direct, low impedance path for fault current to return to the utility transformer. No connection to earth is involved.*

**(4) – Bonding of Electrically Conductive Materials and Other Equipment – Electrically conductive materials** that are likely to become energized shall **be connected together and to the electrical supply source** in a manner that establishes **an effective ground-fault current path**.

**(5) – Effective Ground-Fault Current Path – Electrical equipment** and wiring and other electrically conductive material likely to become energized shall be installed in a manner that creates **a permanent, low-impedance** circuit capable of **safely carrying the maximum ground-fault current** likely to be imposed on it **from any point on the wiring system** where a ground fault may occur **to the electrical supply source**. The **earth shall not be used as the** sole equipment grounding conductor or **effective ground-fault current path**.

*Grounding systems and equipment does not provide a low impedance path for fault current. Bonding equipment and connecting it to the service neutral does provide this required path.*

## WHICH SERVICES TO GROUND

Section 250.20 (A) through Section 250.20 (D) identifies those services that are required to be grounded. For all practical purposes, every service 600 volts or less supplying general premises wiring is required to be grounded. The only systems not required to be grounded are single phase, 2-wire 240 or 480V systems and three phase, 3-wire delta connected 240 or 480V systems. These systems are generally found in industrial applications to feed specific types of equipment such as motors or electric heaters.

Systems not required to be grounded may be voluntarily grounded. An example of this is the three phase, 3-wire delta connected 480V system which has one phase (corner) grounded.

### 250.20 – Requirements for Grounding Alternating-Current Systems of 50 Volts to 1,000 Volts

AC systems supplying **premises wiring** and **premises wiring systems** shall be grounded under any of the following conditions.

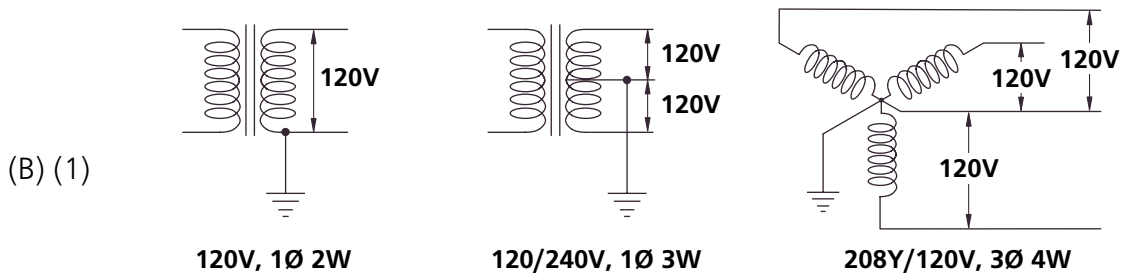

The neutrals must be grounded because the maximum **voltage to ground** from any ungrounded conductor does not exceed 150 volts.

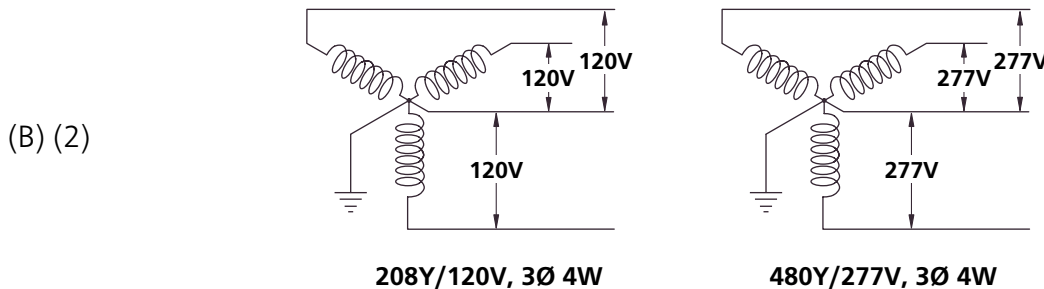

Where the system is three phase, four wire, wye connected in which the neutral is used as a circuit conductor.

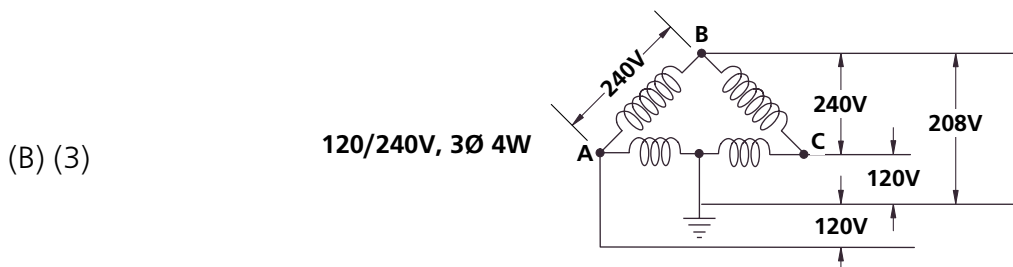

Where the system is three phase, four wire, delta connected in which the midpoint on one phase winding is used as a circuit conductor.

CAUTION: There exists a "high leg" (208V) voltage from the B phase to ground. The B phase is only to be used in 240V 3 phase or 240V single phase applications.

## HOW TO GROUND THEM

A *Grounding Electrode Conductor* is used to connect the grounded service conductor (neutral) to a *Grounding Electrode* installed in the earth or in the foundation of the building served. 250.24 (A) identifies the requirement for a *Grounding Electrode Conductor* to be connected to the *Grounded Service Conductor*.

**250.24 (A) — System Grounding Connections** — A premises wiring system supplied by a grounded AC service shall have a grounding electrode conductor connected to the grounded service conductor, at each service, in accordance with 250.24 (A) (1) through 250.24 (A) (5).

250.24 (C) requires the *Grounding Electrode Conductor* to connect:

the equipment grounding conductors;

the service equipment enclosures; and,

the service neutral to earth using one or more of the *Grounding Electrodes* identified in 250.52.

The purpose of this connection is to provide a direct path to earth for lightning or high voltage on the premises wiring system. More importantly, this connection to earth helps to stabilize system voltage under normal operating conditions.

**250.24 (C) — The Grounding Electrode Conductor** — A grounding electrode conductor shall be used to connect the equipment grounding conductors, the service-equipment enclosures, and, where the system is grounded, the grounded service conductor to the grounding electrode(s) required by Part III of this article.

High-impedance grounded neutral system connections shall be made as covered in 250.36.

FPN: See 250.24 (A) for AC system grounding connections.

 Bus insulated from enclosure

 Bus bonded to enclosure

*Ungrounded conductors are not shown in illustrations.*

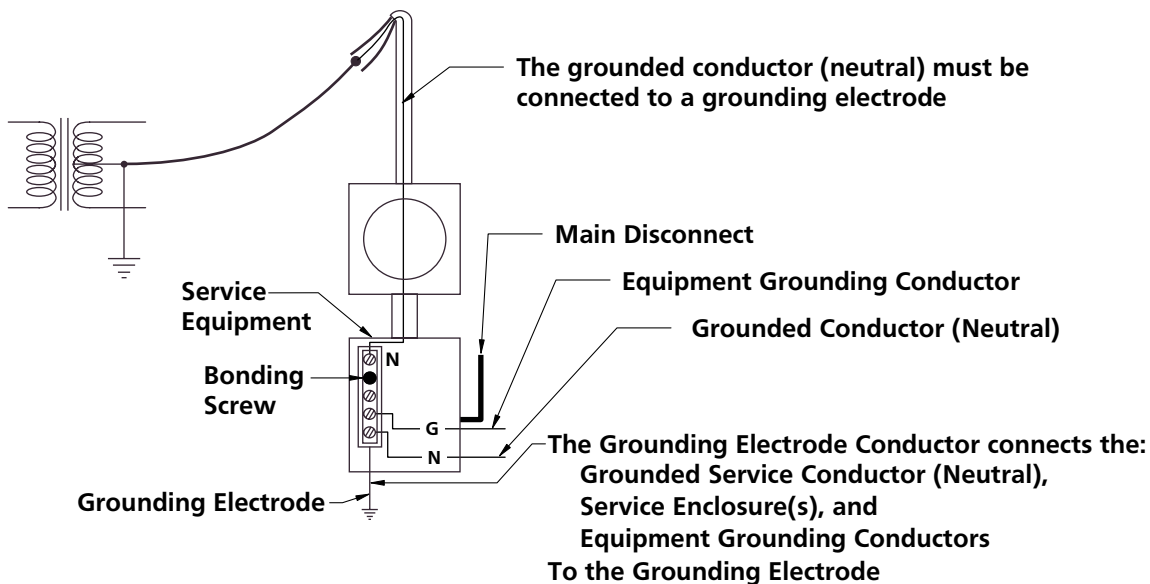

**For details on Types of Grounding Electrodes, the Grounding Electrode System and the size and installation requirements for Grounding Electrode Conductors, see Pages 14 through 19.**

## CONNECTING THE GROUNDING ELECTRODE CONDUCTOR

250.24 (A) (1) through (5) regulate the connection of the Grounding Electrode Conductor to the neutral. (A) (1) identifies where the connection can be made.

**250.24 (A) (1) – General** – The connection shall be made at any accessible point from the load end of the service drop or service lateral to and including the terminal or bus to which the grounded service conductor is connected at the service disconnecting means.

FPN: In Article 100 of this pamphlet, see definitions of Service Drop (page 3) and Service Lateral (page 3).

Although this section would permit the grounding electrode to be connected to the neutral at the weather-head on an overhead service (load end of the service drop) or in the utility landing section of an underground service panel (load end of the service lateral), these would be extremely unusual connections. Most typically, the grounding electrode conductor is connected directly to the neutral bus in the service panel. 250.24 (A) (4) allows the Grounding Electrode Conductor to be connected to the Equipment Grounding Terminal in the Service Panel when the Main Bonding Jumper is a wire or busbar.

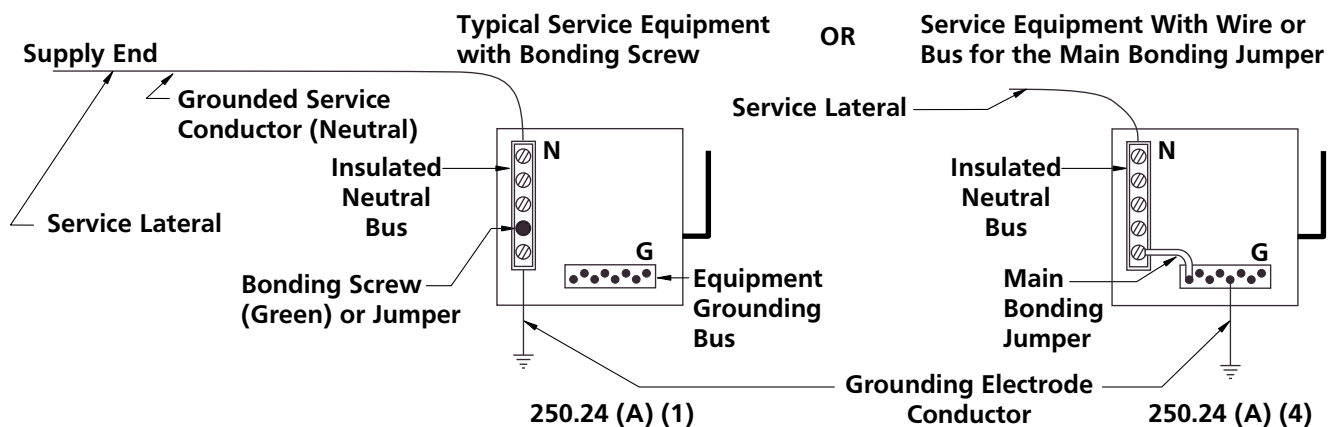

250.24 (A) (2) requires a second grounding electrode when the serving transformer is outside of the structure.

250.24 (A) (3) covers special requirements for dual fed services.

250.24 (A) (5) prohibits the re-grounding of the neutral at any point on the system past the main disconnect.

**250.24 (A) (5) – Load-Side Grounding Connections** – A grounding connection shall not be made to any grounded circuit conductor on the load side of the service disconnecting means except as otherwise permitted in this article.

FPN: See 250.30 (A) for separately derived systems, 250.32 for connections at separate buildings or structures, and 250.142 for use of the grounded circuit conductor for grounding equipment.

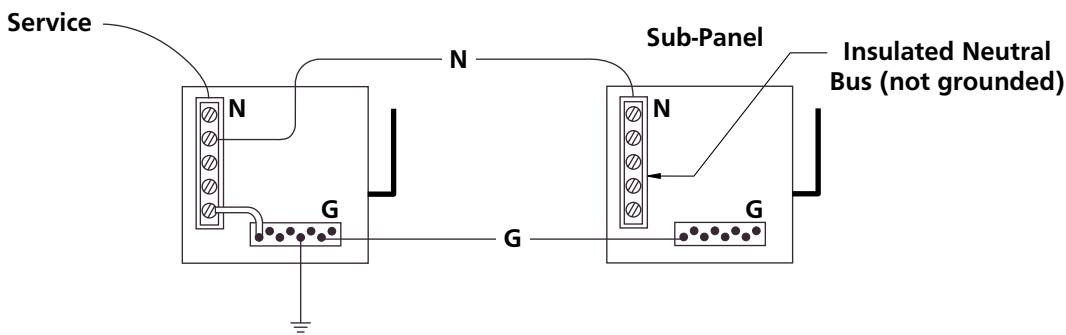

## GROUNDING AT SEPARATE BUILDINGS

*A significant revision of the 1999 NEC changed the long standing rule for grounding separate buildings supplied by a common service. Prior to this change, the basic rule was to treat the main panel in the separate building as if it were a service panel.*

*The changes in the 1999 and 2002 NEC recognize that re-grounding the neutral in a separate building creates a parallel path which permits normal neutral current to flow on any equipment grounding conductor or any other metal common to both buildings. This objectionable current is exactly why neutrals are not permitted to be re-grounded in panels in the same building.*

*The basic rule for panels in a separate building is that the feeder contain an equipment grounding conductor and the panel be treated the same as a sub-panel in the same building—with one exception.*

*A grounding electrode is required at the separate building (for protection from lightning and high voltage) and the equipment grounding conductor in the feeder, the panel and anything in the separate building required to be grounded are connected to this grounding electrode. **The neutral remains isolated.***

*The grounding electrode requirement is waived for separate buildings served by a single branch circuit.*

### **250.32 — Two or More Buildings or Structures Supplied From a Common Service**

**(A) — Grounding Electrode** — Where two or more buildings or structures are supplied from a common ac service by a feeder(s) or branch circuit(s), the grounding electrode(s) required in Part III of this article at each building or structure shall be connected in the manner specified in 250.32 (B) or 250.32 (C). Where there are no existing grounding electrodes, the grounding electrode(s) required in Part III of this article shall be installed.

Exception: A grounding electrode at separate buildings or structures shall not be required where only one branch circuit supplies the building or structure and the branch circuit includes an equipment grounding conductor for grounding the conductive non-current-carrying parts of all equipment.

**(B) — Grounded Systems** — For a grounded system at the separate building or structure, the connection to the grounding electrode and grounding or bonding of equipment, structures, or frames required to be grounded or bonded shall comply with either 250.32 (B) (1) or 250.32 (B) (2).

**(1) — Equipment Grounding Conductor** — An equipment grounding conductor as described in 250.118 shall be run with the supply conductors and connected to the building or structure disconnecting means and to the grounding electrode(s). The equipment grounding conductor shall be used for grounding or bonding of equipment, structures, or frames required to be grounded or bonded. The equipment grounding conductor shall be sized in accordance with 250.122. Any installed grounded conductor shall not be connected to the equipment grounding conductor or to the grounding electrode(s).

*250.32 (B) (2) allows the neutral to be re-grounded at the separate building under some very restrictive conditions.*

*First, the feeder to the separate building cannot contain an equipment grounding conductor. This means the feeder cannot be run in any wiring method that is an equipment grounding conductor such as Rigid or EMT or in any cable assembly that includes an equipment grounding conductor such as MC, AC, SE, UF and NM. If an equipment grounding conductor is run to the separate building, then the neutral cannot be re-grounded.*

*Second, there can be no other “continuous metallic paths” between the two buildings such as metal gas or water piping or the metal armor of cable assemblies. If any such paths exist, and they are quite common, then the neutral cannot be re-grounded.*

*Third, if there is Ground Fault Protection on the service, then the neutral cannot be re-grounded.*

**(2) — Grounded Conductor** — Where (1) an equipment grounding conductor is not run with the supply to the building or structure, (2) there are no continuous metallic paths bonded to the grounding system in both buildings or structures involved, and (3) ground-fault protection of equipment has not been installed on the common AC service, the grounded circuit conductor run with the supply to the building or structure shall be connected to the building or structure disconnecting means and to the grounding electrode(s) and shall be used for grounding or bonding of equipment, structures, or frames required to be grounded or bonded. The size of the grounded conductor shall not be smaller than the larger of either that required by 220.22 or that required by 250.122.

*These conditions eliminate all wiring methods with the exception of PVC or overhead open conductors and all separate buildings where the metal gas or water piping is bonded in both buildings. In short, there are few installations where the neutral can be re-grounded at a separate building. On the other hand, almost every installation can comply with 250.32 (B) (1) simply by keeping the neutral isolated at the separate building.*

*250.32 (D) recognizes the limited case where the disconnect for a separate building is permitted to be located somewhere away from the building. This subsection requires the installation of an enclosure, located immediately inside or outside of the separate building, to provide a connection point for the equipment grounding conductor to the grounding electrode conductor. **The neutral remains isolated.** See 225, Part II for the rules pertaining to disconnects for separate buildings served by a common service.*

#### **A NOTE ON SERVICE EQUIPMENT MARKING**

Panels intended for use as service equipment come with two different markings depending on their construction. These markings are "Suitable Only for Use as Service Equipment" and "Suitable for Use as Service Equipment."

Panels marked "Suitable Only for Use as Service Equipment" have the neutral bus permanently bonded to the can. Because of this connection, these panels cannot be used as sub-panels.

Panels marked as "Suitable for Use as Service Equipment" have an isolated neutral bus but provide a screw or jumper which can be used to bond the neutral bus to the can. This allows the panel to be used either as service equipment or as a sub-panel.

Reference: UL 869A

## SERVICE BONDING

250.28 requires the Main Bonding Jumper to connect the equipment grounding conductors and the service equipment enclosures to the service neutral. The Main Bonding Jumper is not intended to connect any part of the electrical system to earth. The purpose of the bonding connection at the Service is to create a low impedance path for ground fault current to return directly to the transformer on the service neutral conductor. When a ground fault occurs, the low impedance of this path assures a high fault current returning to the transformer which forces an overcurrent device to trip. The path through earth to the transformer is a high impedance path which typically restricts the flow of fault current to levels below the trip setting of the overcurrent device.

**250.28 — Main Bonding Jumper** — For a grounded system, an unspliced main bonding jumper shall be used to connect the equipment grounding conductor(s) and the service-disconnect enclosure to the grounded conductor of the system within the enclosure for each service disconnect.

Exception No. 1: Where more than one service disconnecting means is located in an assembly listed for use as service equipment, an unspliced main bonding jumper shall bond the grounded conductor(s) to the assembly enclosure.

Exception No. 2: Impedance grounded neutral systems shall be permitted to be connected as provided in 250.36 and 250.186.

**(A) — Material** — Main bonding jumpers shall be of copper or other corrosion-resistant material. A main bonding jumper shall be a wire, bus, screw, or similar suitable conductor.

**(B) — Construction** — Where a main bonding jumper is a screw only, the screw shall be identified with a green finish that shall be visible with the screw installed.

**(C) — Attachment** — Main bonding jumpers shall be attached in the manner specified by the applicable provisions of 250.8.

**(D) — Size** — The main bonding jumper shall not be smaller than the sizes shown in Table 250.66 for grounding electrode conductors. Where the service-entrance phase conductors are larger than 1100 kcmil copper or 1750 kcmil aluminum, the bonding jumper shall have an area that is not less than 121/2 percent of the area of the largest phase conductor except that, where the phase conductors and the bonding jumper are of different materials (copper or aluminum), the minimum size of the bonding jumper shall be based on the assumed use of phase conductors of the same material as the bonding jumper and with an ampacity equivalent to that of the installed phase conductors.

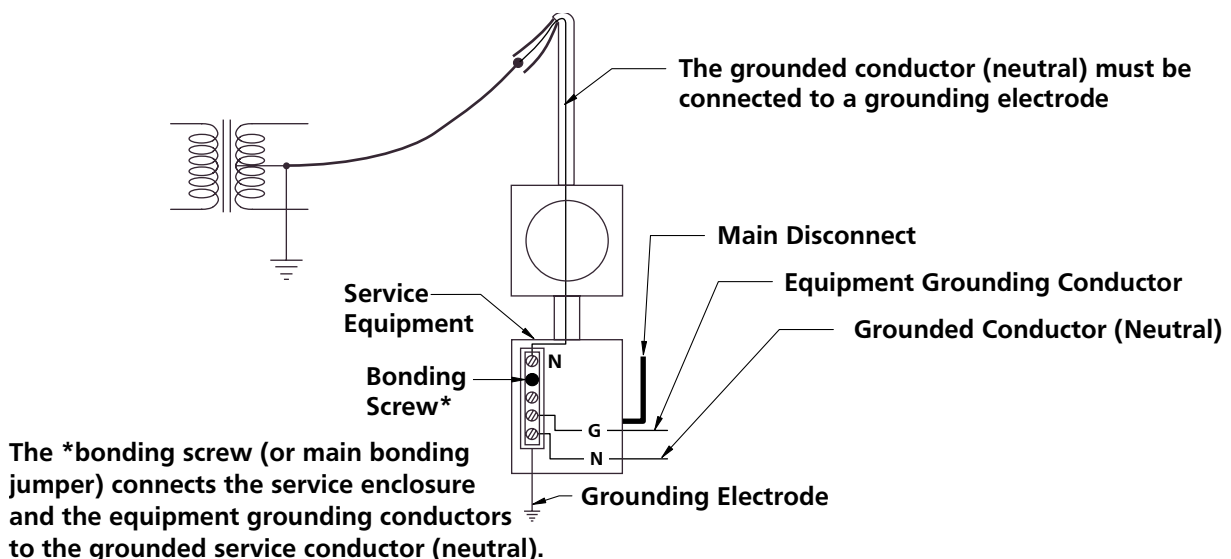

## **BONDING SERVICE EQUIPMENT**

**250.92 (A)** requires that all equipment or raceways enclosing service conductors be bonded together. This includes both ends of any raceway or armor enclosing a grounding electrode conductor.

*An overhead-supplied, residential service might include the weatherhead, the service riser, a separate meter enclosure, a raceway or nipple between the meter enclosure and the main service panel, the main service panel and a raceway enclosing the grounding electrode conductor. More typically, a residential overhead service consists of the weatherhead, the service riser, an all-in-one meter-main with an armored grounding electrode conductor.*

**250.94** requires that this bonding be accomplished by one of the following methods:

- (1) *By bonding to the grounded service conductor. For example, the bond screw connects the service panel to the neutral bus.*
- (2) *By threaded fittings or threaded bosses on enclosures. Standard threaded couplings on rigid conduit in the service riser with the rigid conduit threaded into a hub or boss on the service panel. Bolt-on hubs listed for service bonding are acceptable.*
- (3) *By threadless (compression) couplings or connectors. Standard compression couplings on EMT in the service riser with a threadless connector threaded into a hub or boss on the service panel. Bolt-on hubs listed for service bonding are acceptable.*
- (4) *By other approved devices, such as listed, bonding type locknuts and bushings. Most typically used on nipples between separate pieces of equipment such as a separate meter box and main panel or on the raceway enclosing the grounding electrode conductor.*

*Connectors and couplings are required to be properly installed and made up wrench tight.*

*Standard locknuts or bushings are not acceptable for bonding service equipment.*

***The intent of bonding service equipment is to assure that resistance between the separate pieces of equipment is as close to zero as possible. In effect, bonding causes the separate pieces of equipment to perform as if they were a single piece of electrically conductive material. This is important under fault conditions since it minimizes any voltage difference between the separate pieces of equipment and assures that fault current has a direct, low resistance path to the neutral and on to the transformer.***

## **BONDING OTHER ELECTRICAL EQUIPMENT**

**250.96** requires all other electrical equipment to be bonded together. The intent is to assure electrical continuity and the ability to safely conduct the maximum fault current the connection may be required to carry. Standard locknuts and bushings are acceptable. Connections must be clean with solid metal to metal contact.

**250.97** adds special requirements for circuits operating at over 250 volts to ground. This includes all 480 volt single and three phase feeders and circuits. The basic rule requires these circuits to be bonded using the methods listed for bonding service equipment, except for bonding to the neutral. The exception to the rule allows standard bonding where there are no concentric knockouts. If a half-inch conduit is installed in a half-inch opening with no larger knockouts, standard bonding is acceptable. Standard bonding includes threaded and threadless connections, locknuts inside and outside of the box, fittings with shoulders and a locknut inside the box and fittings listed for the purpose. It should be noted that all commercially available conduit couplings and connectors are listed for bonding.

**250.102** covers the material, sizing and installation of equipment bonding jumpers. Where the equipment bonding jumper is a conductor and is installed on the supply side of the service, it is required to be sized according to Table 250.66, the same as the main bonding jumper. Where the equipment bonding jumper is a conductor and is installed on the load side of the service, it can be sized according to Table 250.122.

## **OTHER BONDING**

**250.104** covers bonding of metal water piping, other metal piping and structural steel in or on a premises.

**250.104 (A)** requires metal water piping to be bonded to the electrical grounding electrode system with a bonding jumper sized according to Table 250.66. The point of connection must be accessible. Note that this requirement applies whether or not the water piping is being used as a grounding electrode. Metal water bonding is required to be bonded because it is possible for it to become energized. Should that occur, bonding provides a low resistance path for fault current to return to the neutral at the service. Every bonding connection is a link in the effective Ground-Fault Current Path required by 250.4 (E).

**250.104 (B)** requires other metal piping, such as gas piping, to be bonded. Gas piping is named specifically to make it clear that bonding of the premises gas piping system is required. The bonding jumper is sized according to Table 250.122 based on the size of the largest circuit that might energize the gas piping.

Note that 250.52 (B) (2) prohibits the use of underground gas piping as a grounding electrode conductor. The only effective method to comply with both of these requirements is to install an isolating fitting between the underground gas piping and the premises gas piping. The premises gas piping system must be bonded for the same reason noted for metal water piping.

**250.104 (C)** requires exposed structural steel framing to be bonded. The bonding jumper is sized according to Table 250.66.

## EQUIPMENT GROUNDING (BONDING)

**250.110** and **250.114** effectively require every piece of electrical equipment to be “grounded.”

**250.118** identifies the types of equipment grounding conductors including which wiring methods are equipment grounding conductors in their own right (such as Rigid and EMT) and which, by omission require a separate equipment grounding conductor (such as Rigid Nonmetallic Conduit).

**250.122** covers the size of equipment grounding conductors.

However, to ground equipment means, by definition, to connect it to earth which provides protection against lightning and high voltage. Is such protection necessary for a metal receptacle box in an interior wall of a dwelling? If that box is struck by lightning (or hit with high voltage), then the lightning is already surging throughout the structure. Is the No. 14 copper conductor running from the box to the service and connected to the grounding electrode conductor going to channel the lightning to earth? Not likely. Lightning is quite similar to an 800-pound gorilla. So where does an 800-pound gorilla go? ANYWHERE IT WANTS!

It should be apparent that, notwithstanding the ongoing requirements to “ground” everything, the equipment grounding conductor serves a far more important role in the electrical system than making a connection to earth.

In point of fact, the equipment grounding conductor actually forms the “effective ground-fault current path” described in 250.4 (E). This path protects the premises wiring system from ground faults by providing a low resistance path for fault current on metal equipment to return directly to the transformer on the grounded service conductor. The connection to earth plays no part in this function. If a hot conductor inadvertently contacts that metal box in a dwelling wall mentioned above, current will flow from the box onto the equipment grounding conductor, through the equipment grounding conductor to the service, onto the neutral and directly to the transformer.

If the equipment grounding conductor is properly sized and correctly installed, the total resistance in this path will typically be less than 1 ohm. On a 120 volt circuit, this allows approximately 120 amps of fault current to flow and forces an overcurrent device (the 20A branch circuit breaker) to operate. By comparison, the path through earth from a service to the utility transformer will almost always exceed 10 ohms. If the equipment grounding conductor were connected only to the grounding electrode, the fault current would be limited to 12 amps or less and certainly would not trip a 20A breaker. The fault current would continue to flow and anyone who contacted the energized metal would be shocked and possibly electrocuted.

The point of this discussion is to make it clear that, while grounding (the connection to earth) performs an important role at services, most of what continues to be called grounding on the premises wiring system is really a requirement to create an effective ground-fault current path. This path is from any point on the system where a fault may occur, to the service, onto the service neutral and directly to the transformer. No connection to earth or “grounding” is involved. The connection to the service neutral provides a low resistance return path to the transformer and allows maximum fault current to flow which forces an overcurrent device to operate.

Every connection between metal parts (bonding) throughout the premises wiring system is a link in the effective ground-fault current path. A poor connection at any point will interrupt the path and put people in jeopardy. **Be Safe. Bond Well.**

## GROUNDING ELECTRODES

250.50 requires that all grounding electrodes available on the premises be connected together to create a Grounding Electrode System. The types of electrodes most likely to be "available" on the premises are underground metal water piping, the metal frame of the building or a concrete encased electrode. If none of these are available, a made electrode must be installed.

250.52 identifies the acceptable Grounding Electrodes.

250.53 covers the installation of Grounding Electrodes.

## GROUNDING ELECTRODE CONDUCTORS

260.64 describes the installation requirements for Grounding Electrode Conductors.

250.66 and Table 250.66 identify the minimum sizes of Grounding Electrode Conductors.

The following pages provide examples of proper installations of Grounding Electrodes and Grounding Electrode Conductors.

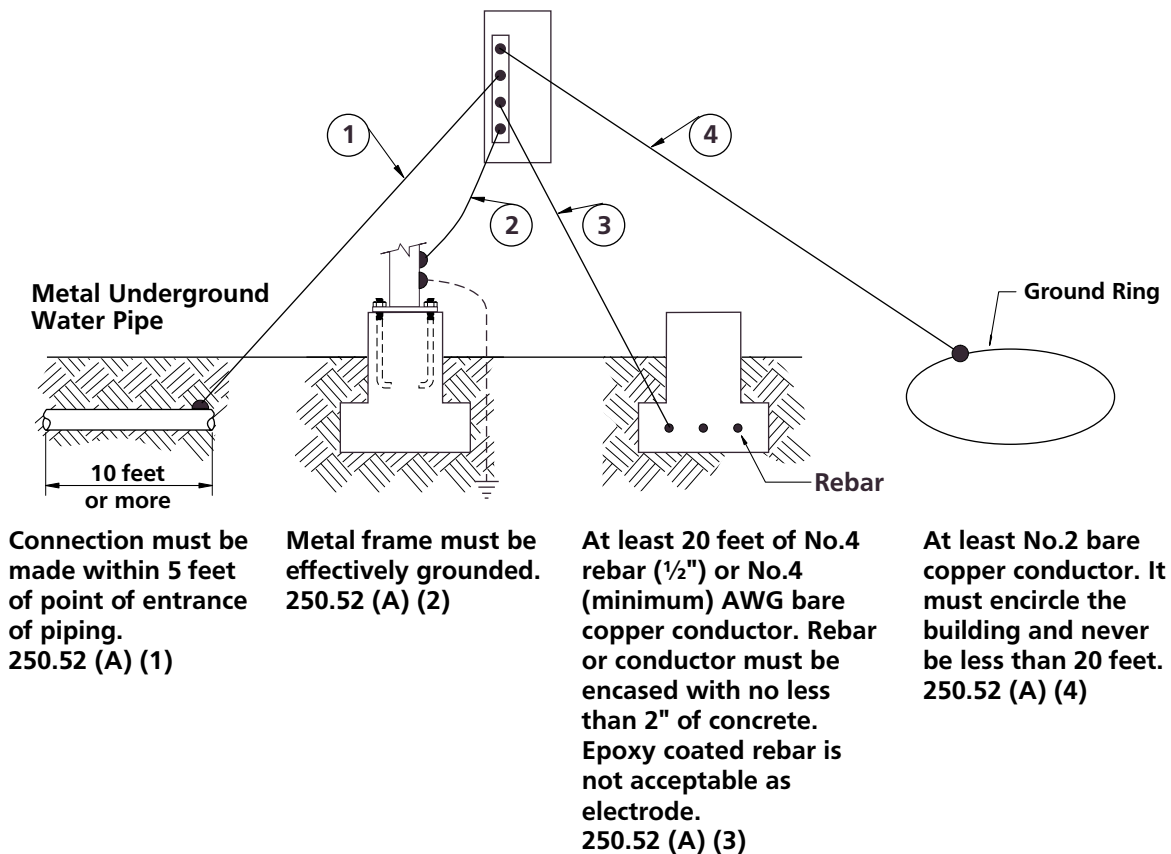

**250.50:** All the grounding electrode conductors shown above are **sole connections** to the service equipment, therefore the exceptions to sizing apply. Minimum sizes for copper grounding electrode conductors are:

- ① No. 8 through 3/0. Use Table 250.66 for sizing.
- ② No. 8 through 3/0. Use Table 250.66 for sizing.
- ③ No. 8 through No. 4 Use Table 250.66 for sizing. It is never required to be larger than No. 4 regardless of the size of the service conductors, 250.66 (B).
- ④ The sole connections never have to be larger than the ground rings, 250.66 (C).

## GROUNDING ELECTRODE SYSTEM

**250.52** — In the following illustration, only (2) is the grounding electrode conductor sized per Table 250-66. Both (1) and (3) are bonding conductors, per 250.52, sized per Table 250.66. (4) is a sole connection to the ground ring, sized per 250.66 (C).

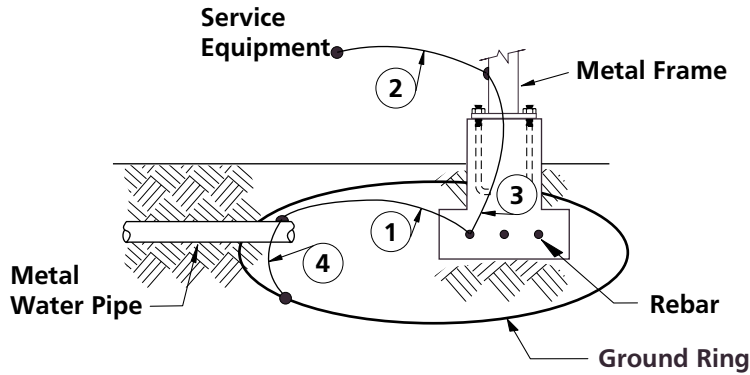

### 250-53 (C) 2

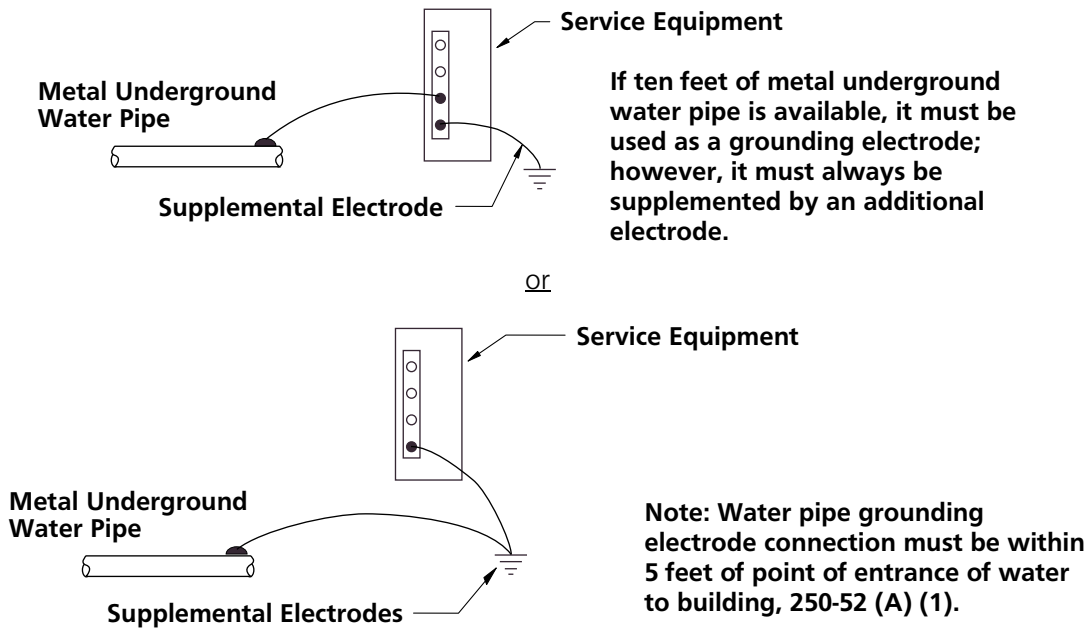

## GROUNDING ELECTRODE SYSTEM (CONT'D)

### 250.52 (A) (3)

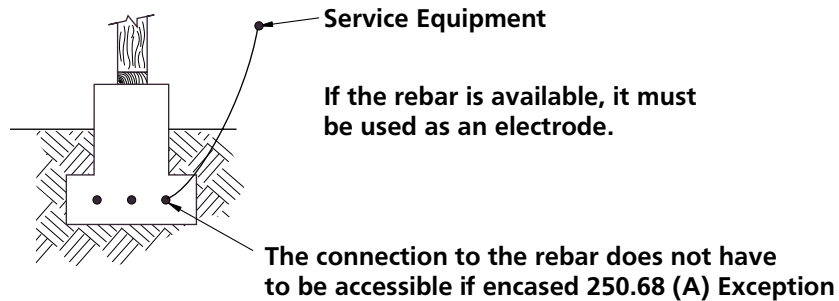

250.50 — If both are available, the steel frame of the building and a concrete encased rebar **must both be used** to form the grounding electrode system.

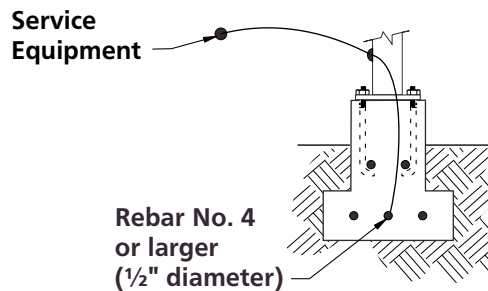

The metal frame of the building must be effectively grounded, 250.52 (A) (2).

The connection of the grounding electrode conductor to the steel frame may be by exothermic welding, 250.70.

The grounding electrode conductor between the service equipment and any convenient part of the grounding electrode system (to the first electrode) must be installed in one continuous length without a splice unless spliced by means of listed irreversible compression connectors or exothermic welding, 250.64 (C). It must always be suitably protected against corrosion, 250.62.

### 250.50:

- The steel frame of a building **may** be used as a sole electrode where effectively grounded, 250.52 (A) (2).
- The concrete encased electrode (Ufer) **may** be used as the sole electrode, 250.52 (A) (3).
- The ground ring may be used as the sole electrode, 250.52 (A) (4).
- A metal underground water pipe **shall not** be used as a sole electrode, 250.53 (D) 2.

## MADE ELECTRODES

### 250.52 – Made and Other Electrodes

Where none of the electrodes specified in section 250.52 (A) (1) through 250.52 (A) (6) is available, one or more of the electrodes specified in 250.52 (A) (4) through 250.52 (A) (7) shall be used. The most commonly used electrode is the **ground rod**.

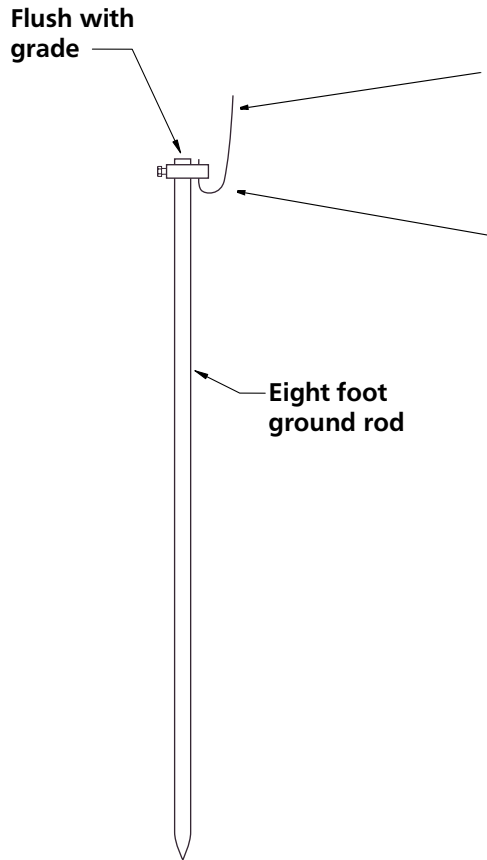

Where the grounding electrode conductor is connected to made electrodes permitted in section 250.52 (A) (4) to (A) (6), the size shall not be required to be larger than No. 6 copper wire. 250.53 (E) It must be a sole connection under this condition.

The connection device must be listed for direct soil burial (250.70). It does not have to be accessible (250.68 (A) Exception).

An eight foot ground rod must be flush or below grade because the NEC requires at least 2.44m (8 ft) to be in contact with the soil (250.53 (G)).

A standard ten foot ground rod can be used, with no less than eight feet in contact with the soil. Any rod projecting above the surface must be protected against physical damage (250.53 (G) 3, 250.10).

A single electrode consisting of a rod, pipe, or plate which does not have a resistance to ground of 25 ohms or less shall be augmented by one additional electrode of the types specified 250.52 (A) (2) through (A) (7) 250-50 or 250-52. Where multiple rod, pipe, or plate electrodes are installed to meet the requirements of this section, they shall be not less than 1.8m (6 ft) apart.

Resistance tests are not required on the supplemental electrode.

## MADE ELECTRODES (CONT'D)

### 250.53 (G) — Rod and Pipe Electrodes

Where rock bottom is encountered, the electrode shall be driven at an oblique angle not to exceed 45 degrees from the vertical or buried in a trench not less than 750mm (30 in) deep.

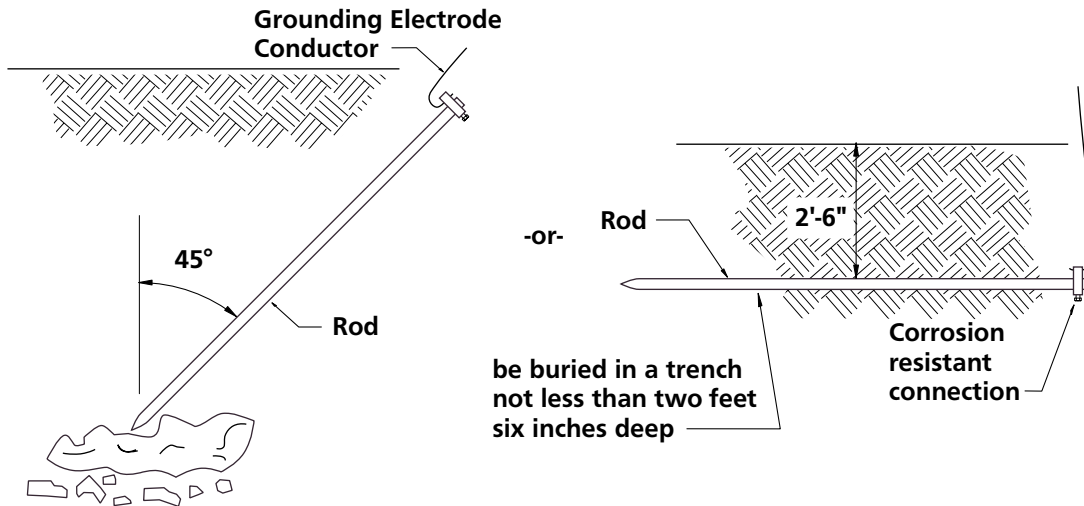

---

### 250.52 (A) (6), 250.53 (H) — Plate Electrodes

The NEC does permit made plate electrodes providing they expose no less than  $0.186\text{m}^2$  ( $2\text{ft}^3$ ) of surface to exterior soil. The wording of "exterior" requires that they be buried **outside** of the building **not** under the building.

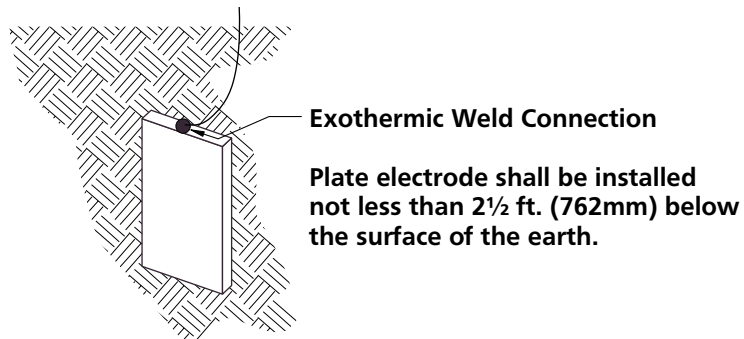

No less than 12" x 12". This dimension will provide one square foot from each of the two surfaces.

Minimum thickness: Iron or steel 6.4mm (¼"), nonferrous metal 1.5mm (0.06 in).

Aluminum electrodes shall not be permitted, 250.52 (B) (2) .

# GROUNDING ELECTRODE CONDUCTOR

## 250-64 (D)

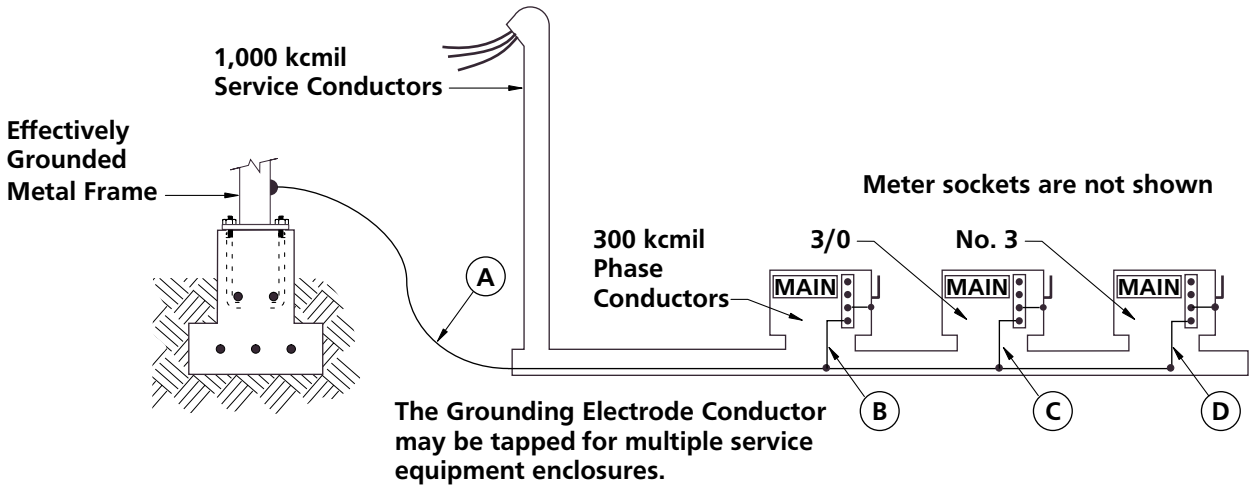

- Ⓐ Size is 2/0      The grounding electrode conductor is based on Table 250.66 for 1,000 kcmil service-entrance conductors.
- Ⓑ Size is No. 2      The grounding electrode conductor tap is based on Table 250.66 for 300 kcmil service conductors.
- Ⓒ Size is No. 4      The grounding electrode conductor tap is based on Table 250.66 for 3/0 service conductors.
- Ⓓ Size is No. 8      The grounding electrode conductor tap is based on Table 250.66 for No. 3 service

## 250.64 – Installation and Protection Requirements for the Grounding Electrode Conductors

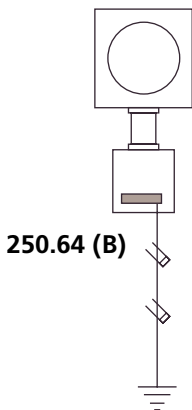

Grounding Electrode Conductor sized No. 4 or larger shall be protected if exposed to severe physical damage.

A No. 6 grounding electrode conductor that is free from physical damage does not require raceway protection. It must be securely fastened to the building.

A No. 8 conductor shall be protected by a raceway or cable armor. Any metallic enclosure, raceway, or cable armor must be electrically continuous by bonding at all terminations and securely fastened to ground clamp or fitting.

