

Reverse-feed applications for circuit breakers



Contents

Description	Page
Introduction	2
Circuit breaker classifications	2
Standards requirements	2
UL 489—Molded case circuit breakers, molded case switches, and circuit-breaker enclosures	2
Testing requirements	2
Marking requirements	3
UL 1066—Low voltage AC and DC power circuit breakers used in enclosures	3
Special application considerations	3
Circuit breakers with integral ground-fault protection	3
Molded case circuit breakers with external ground-fault/earth leakage accessories	4
Miniature circuit breakers with integral ground-fault and arcing-fault protection	5
Summary	6

Introduction

Circuit breakers may be applied in panelboard, switchboard, or motor control center installations where there may occasionally be multiple sources of power, as shown in **Figure 1**. For example, these may be applications that require high “uptime” and high reliability requirements. For these requirements, permanent, fixed mount, or portable electrical generator systems, with an appropriate automatic transfer switching system, are made available to supplement the normal utility power supply source. In other instances, the second power source may be from a so-called “alternate energy source,” such as that derived from solar photo-voltaic or from wind power electric systems. Similarly, these alternate energy sources are also typically connected as a supplement to the normal utility power sources. As electrical load demand conditions change, the user may switch between using power from the normal utility source to the alternate power source, and vice versa. Whenever this switch in power source occurs, the terminals of the circuit breaker that the power is connected to will have been reversed. This reversal in the way that power is connected to a circuit breaker is called “reverse-feed.” Reverse-feed (or “back feed”) refers to a way that the conductors supplying current are connected to a circuit breaker.

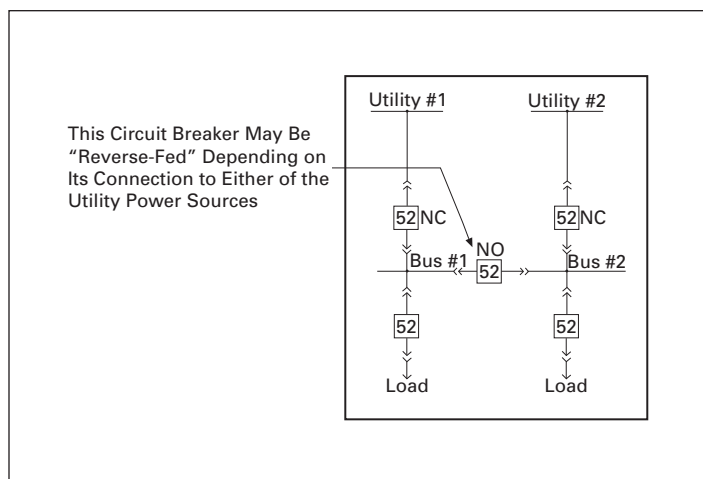

Figure 1. Circuit Breaker Fed from Multiple Power Supply Sources

In other applications where there is a single power source, circuit breakers may be mounted in an electrical enclosure where the cables from the power source are fed to the bottom of the enclosure. In this case, it may be a matter of convenience for the installation to simply connect the power source conductors to the terminals at the bottom of the circuit breaker that are closest to the incoming power supply conductors. This connection of the power supply source to the circuit breaker’s “bottom” terminals will also result in power being applied in a reverse-feed manner.

There are different classifications and types of circuit breakers that exist, and they should be carefully considered when used in reverse-feed applications described above. Depending on the type of circuit breaker, as listed below, reverse-feeding of that circuit breaker may or may not be suitable for that application.

Circuit breaker classifications

Low voltage circuit breakers fall into two basic classifications of design.

1. Molded Case Circuit Breakers (MCCBs)
per UL® 489 Standard
2. Low Voltage Power Circuit Breakers (LVPCBs)
per UL 1066 Standard

Standards requirements

UL 489—Molded case circuit breakers, molded case switches, and circuit breaker enclosures

Per UL 489, there are clear test performance and marking requirements for circuit breakers and molded case switches that are UL Listed as being suitable for reverse-feed applications. UL 489 requires reverse-feed circuit breakers to meet certain construction requirements, and to be tested and marked accordingly, as follows:

1. Tested per UL 489, Paragraph 7.1.1.18
2. Markings per UL 489, Paragraph 9.1.1.13

Testing requirements

Per UL 489, Paragraph 7.1.1.18: *Except for single-pole circuit breakers tested singly, if a circuit breaker is not marked “Line” and “Load,” one sample of each set tested, or one additional sample, shall be connected with the line and load connections reversed during the overload, endurance and interrupting tests.*

This UL test requirement specifies that for circuit breakers and molded case switches to be UL Listed for reverse-feed applications, samples shall be tested with the line and load terminals reverse-fed, as shown in **Figure 2**, and that the test results shall be the same as those of “normally” fed circuit breakers.

Depending on the design configuration and construction, the circuit breaker may or may not be affected by the application of power in a reverse-feed connection during these tests.

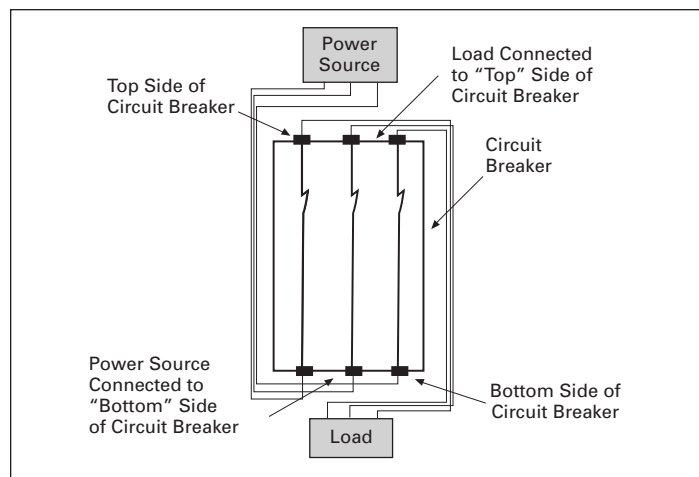

Figure 2. Circuit Breaker Connections for “Reverse-Feed” Testing per UL 489

Marking requirements

Per UL 489 Paragraph 9.1.1.13: *Circuit breakers shall be marked "Line" and "Load" unless the construction and test results are acceptable with the line and load connections reversed.*

This marking requirement specifies that UL Listed circuit breakers and molded case switches shall be marked with the word "Line" on one end of the circuit breaker and the word "Load" on the other end, as shown in **Figure 3**, if they are unable to successfully meet the reverse-feed test requirements per Paragraph 7.1.1.18 of UL 489. Conversely, a UL Listed circuit breaker does not have to be marked with "Line" and "Load" if it successfully meets the reverse-feed test requirements.

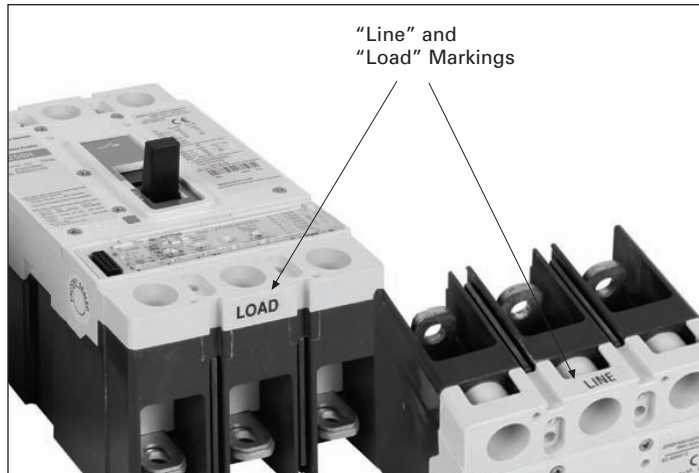

Figure 3. Circuit Breakers Showing "Line" and "Load" Markings, per UL 489

General rule

- Cannot be Reverse-Fed:
When a UL Listed molded case circuit breaker and a molded case switch (not shown) are marked showing "Line" and "Load," the power supply conductors must be connected to the end marked "Line." These devices cannot be reverse-fed.
- Can be Reverse-Fed:
If "Line" and "Load" are not marked on the UL Listed molded case circuit breaker, the power supply conductors may be connected to either end. These devices are suitable for reverse-feed applications.

UL 1066—Low voltage AC and DC power circuit breakers used in enclosures

As part of the standard test programs required by UL 1066 (referenced to ANSI/IEEE® C37.50-1989) for low voltage power circuit breakers, tests are conducted that, when successfully completed, demonstrate that the circuit breaker may be applied in a reverse-feed configuration.

These are mandatory tests that are done as part of the short-circuit current tests per Table 3 in Sequence II (Power-Operated Circuit Breaker with Dual Trip Device) of ANSI/IEEE C37.50-1989. As part of this sequence, tests are "to be performed with opposite terminals energized."

During these specified sequences of tests, the circuit breaker is energized in a reverse-feed configuration, and the satisfactory completion of these tests demonstrates their ability to be used in reverse-feed applications. Therefore, all low voltage power circuit breakers that are listed per UL 1066 may be reverse-fed.

General rule

- Can be Reverse-Fed:
Low voltage power circuit breakers that are listed per UL 1066 may be reverse-fed.

Special application considerations

Circuit breakers with integral ground-fault protection

Many of Eaton's UL Listed molded case and low voltage power circuit breakers have design options and schemes that allow for the detection and interruption of unwanted ground-fault currents. In these ground-fault protection schemes, the means for ground-fault detection are either integral to the circuit breaker or externally mounted.

The ground-fault detection means commonly consist of current sensors and control logic circuitry that may be connected in various configurations as follows:

1. Separate current sensors that monitor each phase circuit and the neutral circuit conductors, as shown in **Figure 4**
2. One current sensor that monitors all phases and the neutral circuit conductors together (not shown)
3. One current sensor that monitors the ground circuit conductor (not shown)

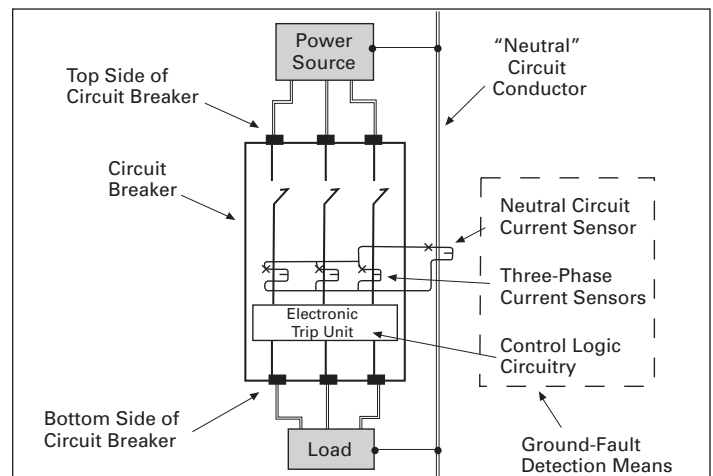

Figure 4. Circuit Breaker with Integral Ground-Fault Protection

The interruption of ground-fault currents is done by the circuit breaker opening all three-phase conductor circuits at the same time, in response to a trip signal from the ground-fault detection means.

Therefore, whenever an unwanted ground-fault condition exists, a UL Listed circuit breaker with ground-fault protection will detect and interrupt the ground-fault current flow.

In reverse-feed applications, while the primary phase currents and the ground currents have been interrupted with the opening of the circuit breaker, voltage at the circuit breaker's terminals may or may not cause damage to the components of the ground-fault protection system. If components in the detection means or control logic circuitry of the ground-fault (or the phase current) protection system may be damaged by reverse-feed connections, then the circuit breaker must be marked accordingly. In this case, where the circuit breaker with ground-fault protection is not suitable for reverse-feed applications, the circuit breaker's terminals are marked with "Line" and "Load" to indicate the required terminal connection points for the power supply source ("Line") and the load ("Load").

Conversely, there are Eaton circuit breaker design configurations where the components in the ground-fault (or phase current) protection system are unaffected by reverse-feed connections, and are suitable for those applications. These circuit breakers are not marked with "Line" and "Load," to indicate that they are suitable for reverse-feed connections—the power supply source may be connected to the terminals at either end of the circuit breaker.

A circuit breaker with integral ground-fault protection may be reverse fed if it is not marked with "Line" and "Load." The UL Listed mark that is applied on this circuit breaker with integral ground-fault protection indicates that it has successfully met the UL test requirements for reverse feed applications.

General rule

- Cannot be Reverse-Fed:
When a UL Listed circuit breaker is marked showing "Line" and "Load," the power supply conductors must be connected to the end marked "Line." These devices cannot be reverse-fed.
- Can be Reverse-Fed:
If "Line" and "Load" are not marked on the UL Listed circuit breaker, the power supply conductors may be connected to either end. These devices are suitable for reverse-feed applications.

Molded case circuit breakers with external ground-fault/earth leakage accessories

There are ground-fault current detection schemes that require sensitivity down to relatively low current levels, typically as low as 30 mA. These products are called ground-fault/earth leakage modules.

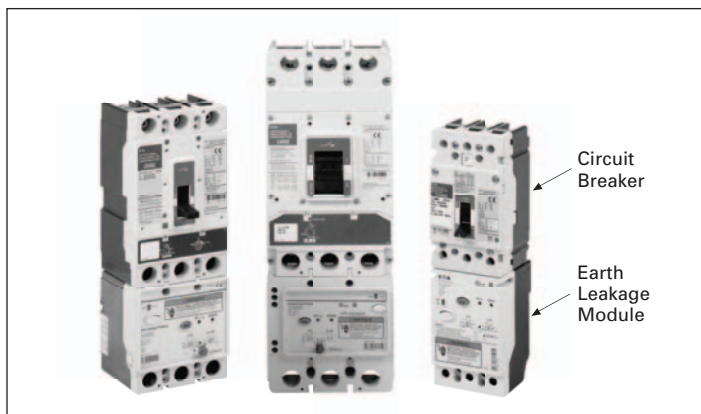

Figure 5. Molded Case Circuit Breakers with Earth Leakage Modules

Eaton's molded case circuit breakers are available with UL Listed ground-fault (earth leakage) modules that are typically mounted external to the "bottom" end of the circuit breaker, as shown in **Figure 5**. These modules are self-contained with a current

sensor and logic control circuitry all located inside the product. Depending on the design configuration and construction of these earth leakage modules, some of these products may or may not be suitable for reverse-feed applications. Each product is marked with a label containing text that describes their suitability for reverse-feed applications, as shown in **Figure 6** and **Figure 7**.

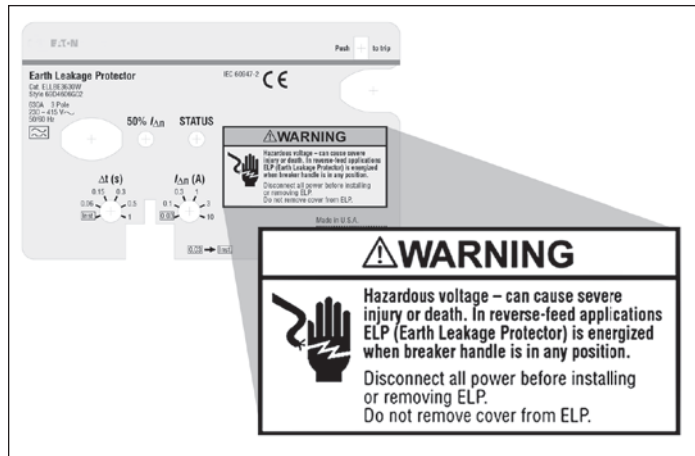

Figure 6. Earth Leakage Module Suitable for Reverse-Feed Applications

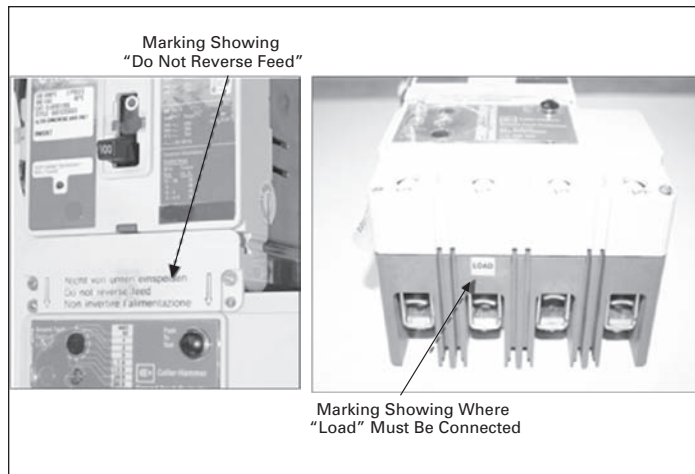

Figure 7. Earth Leakage Modules Not Suitable for Reverse-Feed Applications

Note: The only acceptable combination of circuit breakers and earth leakage modules that should be used in reverse-feed applications is where BOTH 1) the circuit breaker is not marked "Line" and "Load," and 2) the earth leakage module is not marked "Line" and "Load," and not marked "Do not reverse-feed."

General rule

- Cannot be Reverse-Fed:
When either a UL Listed circuit breaker is marked showing "Line" and "Load," or the earth leakage module is marked as unsuitable for reverse-feed, the power supply conductors **MUST** be connected to the "Line" end of the circuit breaker. These devices cannot be reverse-fed.
- Can be Reverse-Fed:
If "Line" and "Load" are not marked on the UL Listed circuit breaker, and the earth leakage module is marked as suitable for reverse-feed, the power supply conductors may be connected to either end. These devices are suitable for reverse-feed applications.

Miniature circuit breakers with integral ground-fault and arcing-fault protection

Eaton’s molded case circuit breakers are available with UL Listed ground-fault current protection levels that are able to detect and trip on ground-fault currents as low as 5 mA for personnel protection, and at 30 mA for sensitive electrical equipment. Eaton also has circuit breakers that provide low-level 30 mA arcing-fault protection in residential applications. The constructions of these circuit breakers are typically in a single-pole or two-pole configuration, and with continuous ampere ratings of 15A through 100A. Due to their relative small size and low continuous ampere ratings, these types of molded case circuit breakers are commonly called “miniature circuit breakers.”

- The 5 mA designs for personnel protection are known as ground-fault circuit interrupters (GFCI)
- The 30 mA designs for equipment protection are known as ground-fault equipment protectors (GFEP)
- The circuit breaker designs for arcing-fault protection are known as arc-fault circuit interrupters (AFCI)

While the overall performance of the circuit breaker is governed by UL 489 for molded case circuit breakers, the specific 5 mA personnel protection performance is per UL 943 ground-fault circuit interrupters, and the specific 30 mA performance for sensitive electrical equipment is per UL 1053, ground-fault sensing and relaying equipment. The AFCI performance requirements are governed by UL 1699.

For these AFCI, GFCI, and GFEP ground-fault protection designs, when the circuit breaker is closed, the control power for the ground-fault control logic circuitry is typically connected to the “Load” side of the circuit breaker. Whenever a ground-fault condition occurs, the detection means and control logic circuit will operate and cause the circuit breaker’s main current-carrying contacts to open without any intentional delay, and will interrupt the flow of the fault current. This instantaneous trip minimizes electrical shock hazards to personnel in GFCIs, and minimizes the flow of potentially damaging currents to sensitive electrical equipment in GFEP applications. In addition to the interruption of the ground-fault current, the detection means and control logic circuitry also rely on the main current-carrying contacts to open and disconnect the currents that flow through the detection and trip system.

If power is applied to the “Line” terminals, and the load is connected to the “Load” terminals in a “normal” feed configuration, whenever the circuit breaker trips and the main current-carrying contacts open, the ground-fault current is interrupted and control power is also disconnected from the detection means and control logic circuitry of the ground-fault system, as shown in **Figure 8**.

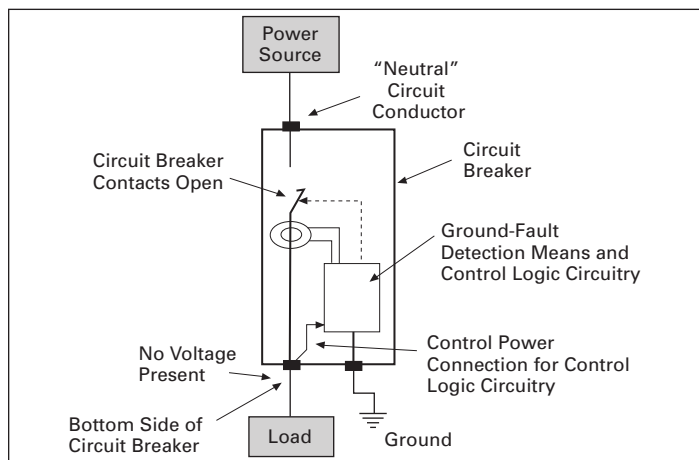

Figure 8. Miniature AFCI, GFCI, and GFEP Circuit Breaker Connected in “Normal” Feed Configuration

When the circuit breaker trips and control power is disconnected from the control logic circuitry, no further current flows through the control logic circuitry to ground.

On the other hand, if power is applied to the “Load” terminals, whenever the AFCI, GFCI, and GFEP circuit breaker trips and the main current-carrying contacts open, the ground-fault current is interrupted, but control power continues to be applied to the ground-fault detection and control logic circuit of the ground-fault system, as shown in **Figure 9**. The presence of the control power will cause current to continually flow through the control logic circuitry. The effect of this continuous current may or may not degrade the performance of the control logic circuitry over time.

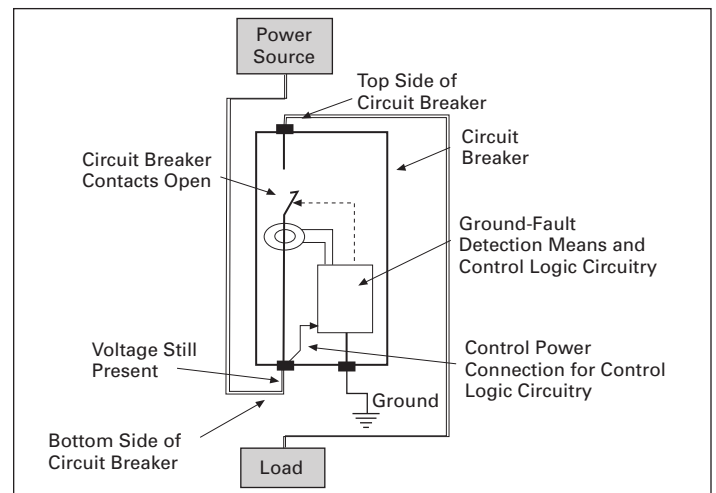

Figure 9. Miniature AFCI, GFCI, and GFEP Circuit Breaker Connected in “Reverse-Feed” Configuration

Depending on the design configuration, the ground-fault detection means and control logic circuit of AFCI, GFCI, and GFEP miniature circuit breakers may be affected by this reverse-feed application. If the AFCI, GFCI, and GFEP circuit breaker is not able to be connected and applied in a reverse-feed configuration, the terminals will be marked “Line” and “Load.”

General rule

- Cannot be Reverse-Fed: When a UL Listed circuit breaker is marked showing “Line” and “Load,” the power supply conductors MUST be connected to the end marked “Line.” These devices cannot be reverse-fed.
- Can be Reverse-Fed: If “Line” and “Load” are not marked on the UL Listed circuit breaker, the power supply conductors may be connected to either end. These devices are suitable to be reverse-feed applications.

Summary

Molded case circuit breakers, UL Listed per UL 489, have specific test and marking requirements to demonstrate that the circuit breaker is suitable for reverse-feed applications.

The capabilities of UL 1066 Listed low voltage power circuit breakers for reverse-feed applications are verified as part of standard circuit breaker test sequences.

- If a circuit breaker and molded case switch are marked “Line” and “Load,” it is not suitable for reverse-feed applications
- Only circuit breakers and molded case switches without “Line” and “Load” markings are suitable for reverse-feed applications

 WARNING

FOR ALL TYPES OF EATON'S CIRCUIT BREAKERS, DO NOT CONNECT THE POWER SOURCE TO CIRCUIT BREAKER TERMINALS MARKED “LOAD.”

For a list of Eaton's circuit breakers that are suitable for reverse-feed applications, visit www.eaton.com.

Eaton Corporation
Electrical Sector
1111 Superior Ave.
Cleveland, OH 44114
United States
877-ETN-CARE (877-386-2273)
Eaton.com

© 2010 Eaton Corporation
All Rights Reserved
Printed in USA
Publication No. PU01200001E / Z9837
May 2010



**PowerChain
Management®**

PowerChain Management is a registered trademark of Eaton Corporation.

All other trademarks are property of their respective owners.